

Liquid Controls Flow Meters

APPLICATION

LC MA series flow meters are mechanical volumetric devices. They provide repetitive and precise volume measurements, regardless unstable working conditions resulting from changes of temperature and pressure of product handled. LC MA series flow meters are manufactured in wide range of sizes and in different material specifications. MA series meters are used at bottling plants, LPG terminals and in many other industrial applications.

Features:

- High precision and repeatability of measurement
- High durability, no direct contact between rotors and internal surface of measuring chamber
- Low pressure drops
- Operation without the need of electrical power or signal conditioning (for units equipped with mechanical registers, printers or presets)
- Can be equipped with electronic registers

PARAMETERS

Flow: 50 - 1325 l/min
Working pressure: 25 - 21,0 bar
Working temperature: -40° do +70° C
Flanges: M-Series: NPT,BSP or weld flanges
 MS-Series: ANSI and DIN flanges

AVAILABLE ACCESSORIES

- Mechanical counter with totalizer
- Printer
- Strainer, air eliminator, pressure control valves, differential valve
- Adapters
- Check valves
- Thermometers
- Presets



Semi-trailer skid installation with MA7 flow-meter

TECHNICAL DATA

| Cat No. Nr | Maximum flow | Size | Connection | Material | Maximum working pressure | |
|---------------|--------------|----------------|--------------|-----------------------------|--------------------------|--------|
| | | | | | 10,5 bar | 25 bar |
| 17.001 | 113 l/min | DN 40 | 1 1/2" | Aluminum | | MA-4 |
| 17.002 | 227 l/min | DN 40 DN 50 | 1 1/2" 2" | Aluminum Stainless steel | M-5 M-5 | MA-5 |
| 17.003 | 380 l/min | DN 50 DN 40 | 2" 1 1/2" | Aluminum Stainless steel | M-7 M-7 | MA-7 |
| 17.004 | 757 l/min | DN 80 | 3" | Aluminum | MS-15 | MA-15 |
| 17.005 | 1325 l/min | DN 80 | 3" | Aluminum | M-30 | MA-30 |

SIZE

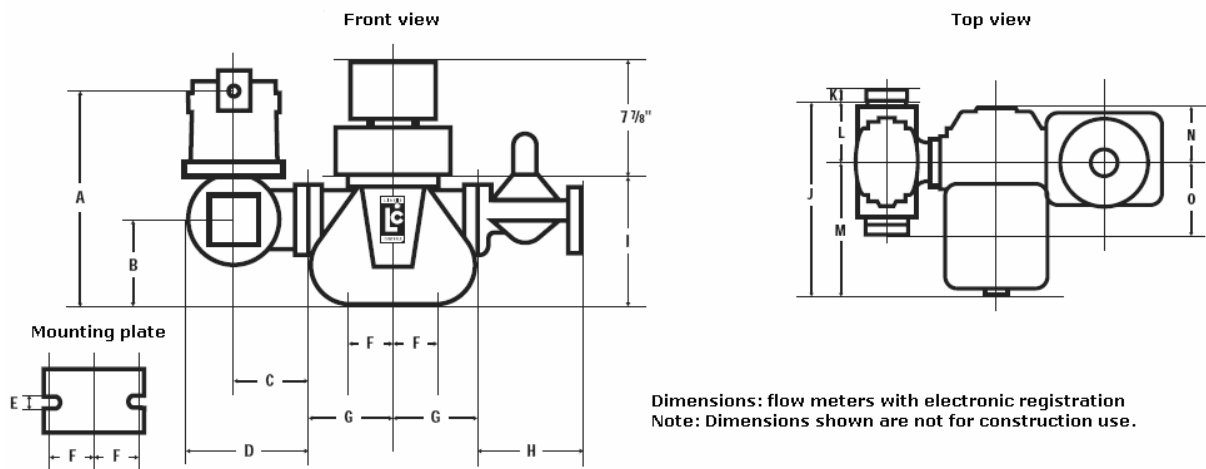

| Mod | | Size | | | | | | | | | | | | | | |
|------|----|------|-----|-----|-----|----|-----|-----|-----|-----|-----|----|-----|-----|-----|-----|
| | | A | B | C | D | E | F | G | H | I | J | K | L | M | N | O |
| M-5 | mm | 360 | 135 | 105 | 172 | 14 | 48 | 125 | 213 | 219 | 352 | 24 | 119 | 233 | 81 | 116 |
| M-7 | mm | 362 | 137 | 105 | 171 | 14 | 71 | 106 | 213 | 241 | 378 | 24 | 119 | 259 | 106 | 141 |
| M-15 | mm | 360 | 135 | 105 | 172 | 14 | 48 | 125 | 213 | 273 | 411 | 32 | 127 | 343 | 129 | 167 |
| M-30 | mm | 521 | 270 | 143 | 230 | 22 | 122 | 200 | n/a | 351 | 494 | 36 | 181 | 313 | 167 | 195 |

STANDARD ACCESSORIES CONFIGURATIONS



Meter with counter

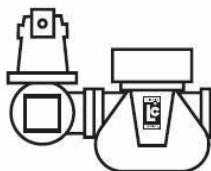

Meter with counter, strainer and air eliminator

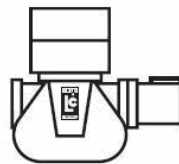

Meter with counter, preset counter and preset valve

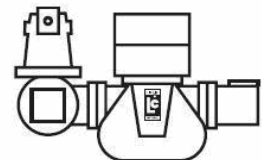

Meter with counter, preset counter, preset valve, strainer and air eliminator