

Flange-type sight flow indicators

APPLICATION

Sight flow indicators are mounted in piping systems and allow for visual control of what content is present in the given section of piping.

MATERIAL SPECIFICATION

The body is made of carbon steel (protected from corrosion), PTFE seals, tempered glass – hardened under pressure according to DIN 8902 standard.

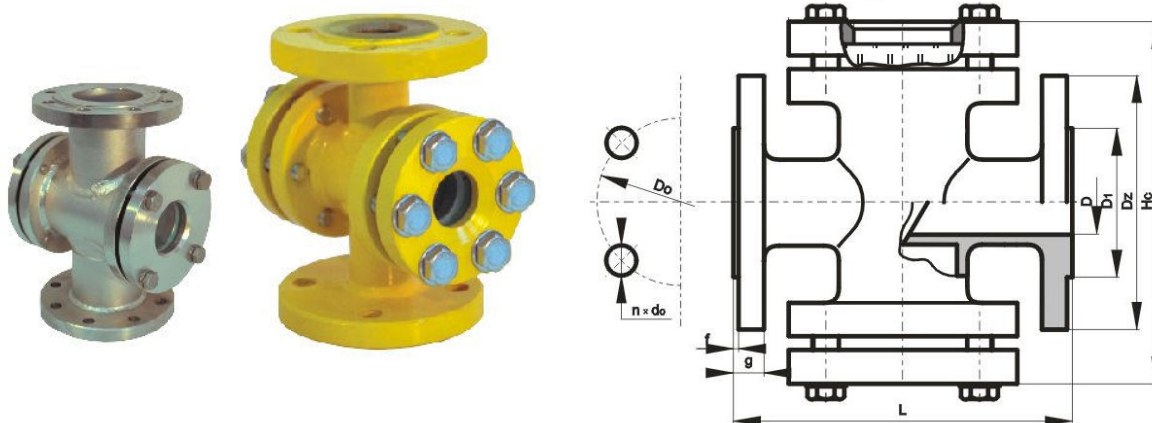

Available sizes:

For pressure PN 16 - from DN20 to DN200;

For pressure PN 25 - from DN20 to DN100;

Maximum working temperature depending on pressures:

6 bar – 280°C;

16 bar – 160°C;

25 bar – 120°C;

Sizes

Cat. No	D/ DN	L	H _c	1,6 / 2,5 MPa							Weight [kg]
				D _o	D _z	D ₁	D _w	g	f	n x d _o	
14.050	20	150	140	75	105	58	30	16/1 8	2	4x14	5,0
14.051	25	160	140	85	115	68	30	16/1 8	2	4x14	5,5
14.052	32	180	140	100	140	78	30	18	2	4x18	7,0
14.053	40	200	218	110	150	88	50	18	3	4x18	14,0
14.054	50	230	218	125	165	102	50	20	3	4x18	20,0
14.055	65	290	218	145	185	122	77	20	3	4x18	29,0
14.056	80	310	258	160	200	133	77	22	3	4x18	34,0
14.057	100	350	258	180/ 190	220/2 35	158	77	24	3	8x18/ 8x22	37,0
14.058	125	400	300	180	250	184	122	26	3	8x18	---
14.059	150	480	350	240	285	212	170	26	3	8x22	---
14.060	200	600	450	295	340	268	170	30	3	8x22	---